



 **PROFILE FC**
user manual

©2024 ELATION PROFESSIONAL all rights reserved. Information, specifications, diagrams, images, and instructions herein are subject to change without notice. ELATION PROFESSIONAL logo and identifying product names and numbers herein are trademarks of ELATION PROFESSIONAL. Copyright protection claimed includes all forms and matters of copyrightable materials and information now allowed by statutory or judicial law or hereinafter granted. Product names used in this document may be trademarks or registered trademarks of their respective companies and are hereby acknowledged. All non-ELATION brands and product names are trademarks or registered trademarks of their respective companies.

ELATION PROFESSIONAL and all affiliated companies hereby disclaim any and all liabilities for property, equipment, building, and electrical damages, injuries to any persons, and direct or indirect economic loss associated with the use or reliance of any information contained within this document, and/or as a result of the improper, unsafe, insufficient and negligent assembly, installation, rigging, and operation of this product.

Elation Professional USA | 6122 S. Eastern Ave. | Los Angeles, CA. 90040

323-582-3322 | www.elationlighting.com | info@elationlighting.com

Elation Professional B.V. | Junostraat 2 | 6468 EW Kerkrade, The Netherlands

+31 45 546 85 66 | +31 45 546 85 96 fax | www.elationlighting.eu | info@elationlighting.eu

Elation Professional Mexico | AV Santa Ana 30 | Parque Industrial Lerma, Lerma, Mexico 52000

+52 (728) 282-7070

DOCUMENT VERSION



Due to additional product features and/or enhancements, an updated version of this document may be available online. Please scan the QR Code with your mobile device or visit www.elationlighting.com for the latest revision/update of this manual, before installation and/or programming.

Date	Document Version	Software Version	DMX Channels	Notes
11/29/2022	1.0	1.0.1	1/5/12/21 Ch, 10/17 CMY, 10/17 RGB	Initial Release
02/22/2023	1.1	N/C	N/C	Update Dimensional Drawings
05/24/2023	1.2	N/C	N/C	Updated Certifications
07/18/2023	1.3	N/C	N/C	Update Specifications
05/31/2024	1.4	N/C	N/C	Updated E-Fly in Menu

CONTENTS

General Information	4
Limited Warranty (USA Only)	5
Safety Precautions	6
Maintenance Guidelines	8
Overview	9
Installation Guidelines	10
Gobos	14
Accessory Installation	17
Zoom and Focus Operation	18
Framing Operation	19
Barrel Rotation	20
Iris Operation	21
Remote Device Management (RDM)	22
Control Panel	23
System Menu	24
E-FLY Wireless DMX Set Up	26
E-FLY Wireless Installation Location Guidelines	27
Fan Control and Low Noise Operation	28
Encoder Modes	29
DMX Traits	30
CTO Table	35
Virtual Colors Table	36
Dimmer Curves	37
Software Updates	38
Error Codes	39
Specifications	40
Dimensional Drawings	41

GENERAL INFORMATION

INTRODUCTION

Please read and understand the instructions in this manual carefully and thoroughly before attempting to operate this device. These instructions contain important safety and use information. **This device is intended for use by trained personnel only, and is not suitable for private use.**

UNPACKING

Every device has been thoroughly tested and has been shipped in perfect operating condition. Carefully check the shipping carton for damage that may have occurred during shipping. If the carton is damaged, carefully inspect the device for damage, and be sure all accessories necessary to install and operate the device have arrived intact. In the event that damage has been found or parts are missing, please contact our customer support team for further instructions. Please do not return this device to your dealer without first contacting customer support. Please do not discard the shipping carton in the trash. Please recycle whenever possible.

BOX CONTENTS

Locking Power Cable (x1)
Designer Gobo Set, 10 Gobos (x1)
Rotating Gobo Holder, installed in fixture (x1)
7.5" Gel Frame (x1)

CUSTOMER SUPPORT

Contact ELATION Service for any product related service and support needs. Also visit forums.elationlighting.com with questions, comments or suggestions.

ELATION SERVICE USA - Monday - Friday 8:00am to 4:30pm PST
323-582-3322 | support@elationlighting.com

ELATION SERVICE EUROPE - Monday - Friday 08:30 to 17:00 CET
+31 45 546 85 63 | Fax +31 45 546 85 96 | support@elationlighting.eu

REPLACEMENT PARTS - please visit parts.elationlighting.com

THERE ARE NO USER SERVICEABLE PARTS INSIDE THIS UNIT. DO NOT ATTEMPT ANY REPAIRS YOURSELF, AS DOING SO WILL VOID YOUR MANUFACTURER'S WARRANTY. DAMAGES RESULTING FROM MODIFICATIONS TO THIS FIXTURE AND/OR THE DISREGARD OF SAFETY INSTRUCTIONS AND GUIDELINES IN THIS MANUAL VOID THE MANUFACTURER'S WARRANTY AND ARE NOT SUBJECT TO ANY WARRANTY CLAIMS AND/OR REPAIRS.

LIMITED WARRANTY (USA ONLY)

- A. Elation Professional hereby warrants, to the original purchaser, Elation Professional products to be free of manufacturing defects in material and workmanship for a period of two years (730 days), and Elation Professional product rechargeable batteries to be free of manufacturing defects in material and workmanship for a period of six months (180 days), from the original date of purchase. This warranty excludes discharge lamps and all product accessories. This warranty shall be valid only if the product is purchased within the United States of America, including possessions and territories. It is the owner's responsibility to establish the date and place of purchase by acceptable evidence, at the time service is sought.
- B. For warranty service, send the product only to the Elation Professional factory. All shipping charges must be pre-paid. If the requested repairs or service (including parts replacement) are within the terms of this warranty, Elation Professional will pay return shipping charges only to a designated point within the United States. If any product is sent, it must be shipped in its original package and packaging material. No accessories should be shipped with the product. If any accessories are shipped with the product, Elation Professional shall have no liability what so ever for loss and/or or damage to any such accessories, nor for the safe return thereof.
- C. This warranty is void if the product serial number and/or labels are altered or removed; if the product is modified in any manner which Elation Professional concludes, after inspection, affects the reliability of the product; if the product has been repaired or serviced by anyone other than the Elation Professional factory unless prior written authorization was issued to purchaser by Elation Professional; if the product is damaged because not properly maintained as set forth in the product instructions, guidelines and/or user manual.
- D. This is not a service contract, and this warranty does not include any maintenance, cleaning or periodic check-up. During the periods as specified above, Elation Professional will replace defective parts at its expense, and will absorb all expenses for warranty service and repair labor by reason of defects in material or workmanship. The sole responsibility of Elation Professional under this warranty shall be limited to the repair of the product, or replacement thereof, including parts, at the sole discretion of Elation Professional. All products covered by this warranty were manufactured after January 1, 1990, and bare identifying marks to that effect.
- E. Elation Professional reserves the right to make changes in design and/or performance improvements upon its products without any obligation to include these changes in any products theretofore manufactured.
- F. No warranty, whether expressed or implied, is given or made with respect to any accessory supplied with the products described above. Except to the extent prohibited by applicable law, all implied warranties made by Elation Professional in connection with this product, including warranties of merchantability or fitness, are limited in duration to the warranty periods set forth above. And no warranties, whether expressed or implied, including warranties of merchantability or fitness, shall apply to this product after said periods have expired. The consumer's and/or dealer's sole remedy shall be such repair or replacement as is expressly provided above; and under no circumstances shall Elation Professional be liable for any loss and/or damage, direct and/or consequential, arising out of the use of, and/or the inability to use, this product.
- G. This warranty is the only written warranty applicable to Elation Professional products and supersedes all prior warranties and written descriptions of warranty terms and conditions heretofore published.

WARRANTY RETURNS

All returned service items whether under warranty or not, must be freight pre-paid and accompanied by a return authorization (R.A.) number. The R.A. number must be clearly written on the outside of the return package. A brief description of the problem, as well as the R.A. number, must also be written down on a piece of paper and included in the shipping container. If the unit is under warranty, you must provide a copy of your proof of purchase invoice. Items returned without an R.A. number clearly marked on the out-side of the package will be refused and returned at customer's expense. You may obtain an R.A. number by contacting customer support.

SAFETY GUIDELINES

This fixture is a sophisticated piece of electronic equipment. To guarantee a smooth operation, it is important to follow all instructions and guidelines in this manual. Elation Professional is not responsible for injury and/or damages resulting from the misuse of this fixture due to the disregard of the information printed in this manual. Only qualified and/or certified personnel should perform installation of this fixture and only the original rigging parts (omega brackets) included with this fixture should be used for installation. Any modifications to the fixture and/or the included mounting hardware will void the original manufacturer's warranty and increase the risk of damage and/or personal injury.



PROTECTION CLASS 1 - FIXTURE MUST BE PROPERLY GROUNDED.



THERE ARE NO USER SERVICEABLE PARTS INSIDE THIS UNIT. DO NOT ATTEMPT ANY REPAIRS YOURSELF; DOING SO WILL VOID YOUR MANUFACTURER'S WARRANTY. DAMAGES RESULTING FROM MODIFICATIONS TO THIS FIXTURE AND/OR THE DISREGARD OF SAFETY INSTRUCTIONS AND GUIDELINES IN THIS MANUAL VOID THE MANUFACTURER'S WARRANTY AND ARE NOT SUBJECT TO ANY WARRANTY CLAIMS AND/OR REPAIRS.



**DO NOT PLUG FIXTURE INTO A DIMMER PACK!
NEVER OPEN THIS FIXTURE WHILE IN USE!
UNPLUG POWER BEFORE SERVICING FIXTURE!
NEVER TOUCH FIXTURE DURING OPERATION, AS IT MAY BE HOT!
KEEP FLAMMABLE MATERIALS AWAY FROM FIXTURE!**



**NEVER LOOK DIRECTLY INTO THE LIGHT SOURCE!
RETINA INJURY RISK - MAY INDUCE BLINDNESS!
SENSITIVE PERSONS MAY SUFFER AN EPILEPTIC SHOCK!**



**INDOOR / DRY LOCATIONS USE ONLY!
DO NOT EXPOSE FIXTURE TO RAIN AND MOISTURE!**



**MINIMUM DISTANCE TO OBJECTS/SURFACES MUST BE 65.6 FEET (20 METERS)
MAXIMUM TEMP OF EXTERNAL SURFACE 185° F (85°C)
MINIMUM DISTANCE OF INFLAMMABLE MATERIALS FROM THE SURFACE 1.6 FEET (0.5 METER)**

SAFETY PRECAUTIONS

- **DO NOT** expose the fixture to rain or moisture, or spill liquids into or onto the fixture! The fixture is intended for use in dry, indoor environments only!
- **DO NOT** shake fixture, and avoid using brute force when installing and/or operating the fixture.
- **DO NOT** operate the fixture if the power cord is frayed, crimped, damaged, and/or if any of the power cord connectors are damaged and do not plug into the fixture securely with ease.
- **NEVER** force a power cord connector into the fixture. If the power cord or any of its connectors are damaged, replace it immediately with a new one of the same power rating.
- **DO NOT** block any air ventilation slots.
- All fan and air inlets must remain clean and never blocked.
- Leave approx. 6" (15cm) between the fixture and other devices or a wall in order to allow for proper cooling.
- Always disconnect the fixture from the main power source before performing any type of service and/or cleaning procedure.
- Only handle the power cord by the plug end. Never pull out the plug by tugging on the wire portion of the cord.
- During the initial operation of this fixture, a light smoke or smell may emit from the interior of the fixture. This is a normal process and is caused by excess paint in the interior of the casing burning off from the heat associated with the lamp. This will decrease gradually over time.
- Consistent operational breaks will ensure fixture will function properly for many years.
- **ONLY** use the original packaging and materials to transport the fixture for service.

MAINTENANCE GUIDELINES



DISCONNECT POWER BEFORE PERFORMING ANY MAINTENANCE!

CLEANING

Frequent cleaning is recommended to ensure proper function, optimized light output, and an extended life. The frequency of cleaning depends on the environment in which the fixture operates: damp, smoky or particularly dirty environments can cause greater accumulation of dirt on the fixture's optics. Periodically clean the external lens surface with a soft cloth to avoid dirt/debris accumulation. **NEVER** use alcohol, solvents, or ammonia-based cleaners.

MAINTENANCE

Regular inspections are recommended to insure proper function and extended life. There are no user serviceable parts inside this fixture. Please refer all other service issues to an authorized Elation service technician. Should you need any spare parts, please order genuine parts from your local Elation dealer.

Please refer to the following points during routine inspections:

- A detailed electric check by an approved electrical engineer every three months, to make sure the circuit contacts are in good condition and prevent overheating.
- Be sure all screws and fasteners are securely tightened at all times. Loose screws may fall out during normal operation, resulting in damage or injury as larger parts could fall.
- Check for any deformations on the housing, color lenses, rigging hardware, and rigging points (ceiling, suspension, trussing). Deformations in the housing could allow for dust to enter into the fixture. Damaged rigging points or unsecured rigging could cause the fixture to fall and seriously injure a person(s).
- Electric power supply cables must not show any damage, material fatigue or sediments.

NEVER remove the ground prong from the power cable.

OVERVIEW

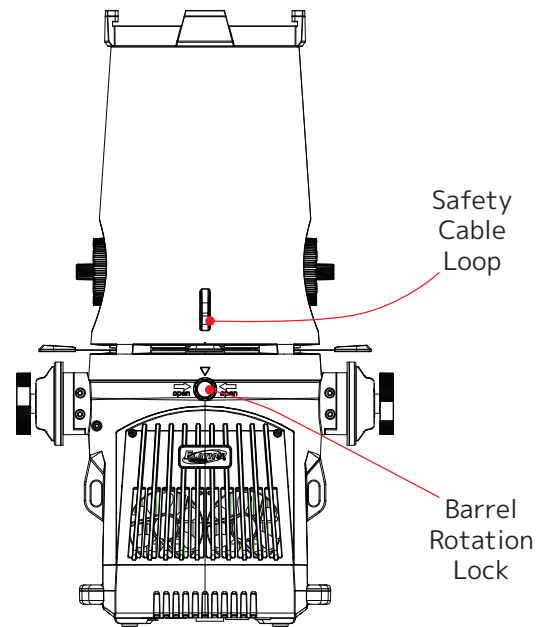
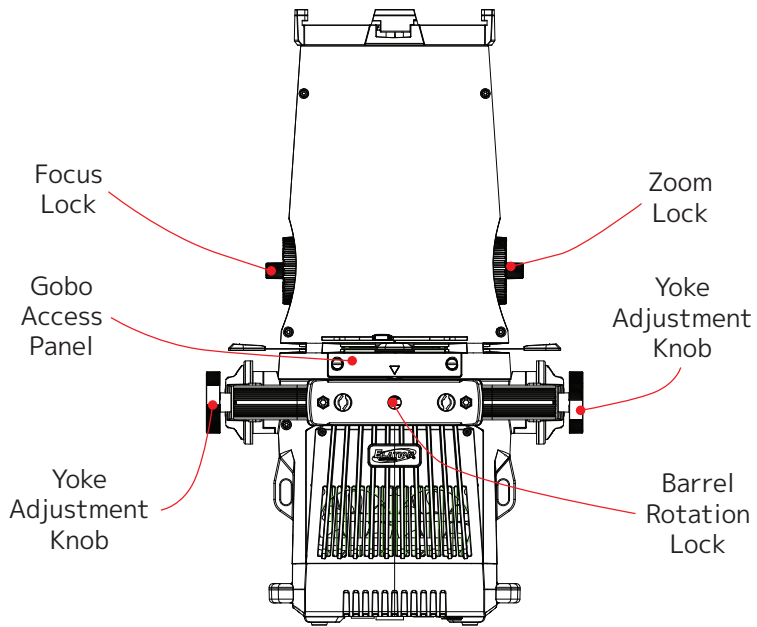
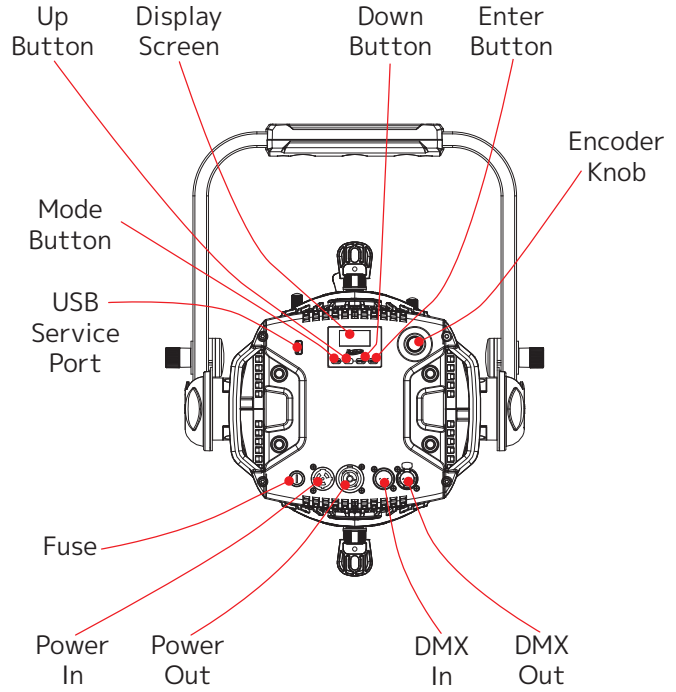
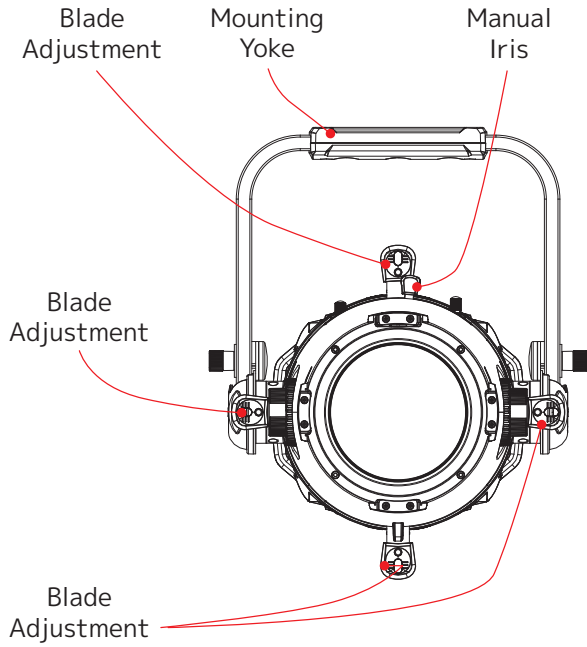

INSTALLATION GUIDELINES



FLAMMABLE MATERIAL WARNING

Keep fixture minimum 5.0 feet (1.5m) away from flammable materials and/or pyrotechnics.



ELECTRICAL CONNECTIONS

A qualified electrician should be used for all electrical connections and/or installations.



MINIMUM DISTANCE TO SURFACES/OBJECTS IS 3.3 FEET (1 METER).

MINIMUM DISTANCE TO FLAMMABLE MATERIALS IS 1.6 FEET (0.5 METER).

MAXIMUM OPERATIONAL AMBIENT TEMPERATURE IS 113° F (45° C).



DO NOT INSTALL THE FIXTURE IF YOU ARE NOT QUALIFIED TO DO SO!

Fixture **MUST** be installed following all local, national, and country commercial electrical and construction codes and regulations.

Before rigging/mounting the fixture to any metal truss/structure or placing the fixture on any surface, a professional equipment installer **MUST** be consulted to determine if the metal truss/structure or surface is properly certified to safely hold the combined weight of the fixture, clamps, cables, and accessories.

Overhead rigging requires extensive experience, including, amongst others, calculating working load limits, installation material being used, and periodic safety inspection of all installation material and the fixture. If you lack these qualifications, do not attempt the installation yourself. Improper installation can result in bodily injury.

Maximum fixture ambient operating temperature is **113°F (45°C)**. Do not operate the fixture when the ambient temperature falls outside of this range.

Do not install outdoors or expose to rain and/or moisture. Fixture is intended for use in dry, indoor areas only.

Fixture(s) should be installed away from walking paths, seating areas, or areas where unauthorized personnel might reach the fixture by hand.

NEVER stand directly below the fixture(s) when rigging, removing, or servicing.

Overhead fixture installation must always be secured with a secondary safety attachment, such as an appropriately rated safety cable.

Allow approximately 15 minutes for the fixture to cool down before servicing.

INSTALLATION GUIDELINES

CLAMP INSTALLATION: Insert a bolt of appropriate size and rating for the desired clamp (not included) through the mounting hole of the clamp (not included), and then insert it into the center hole on the top of the mounting yoke. The bolt should pass through both the clamp and the yoke. Thread a matching washer and locking nut onto the shaft of the bolt that extends out from the underside of the yoke.

SAFETY CABLE: The fixture provides a built-in rigging points for a Safety Cable (not included) on the side of the fixture near the base of the yoke. Be sure to only use the designated rigging point for the safety cable, and never secure a safety cable to a carrying handle.

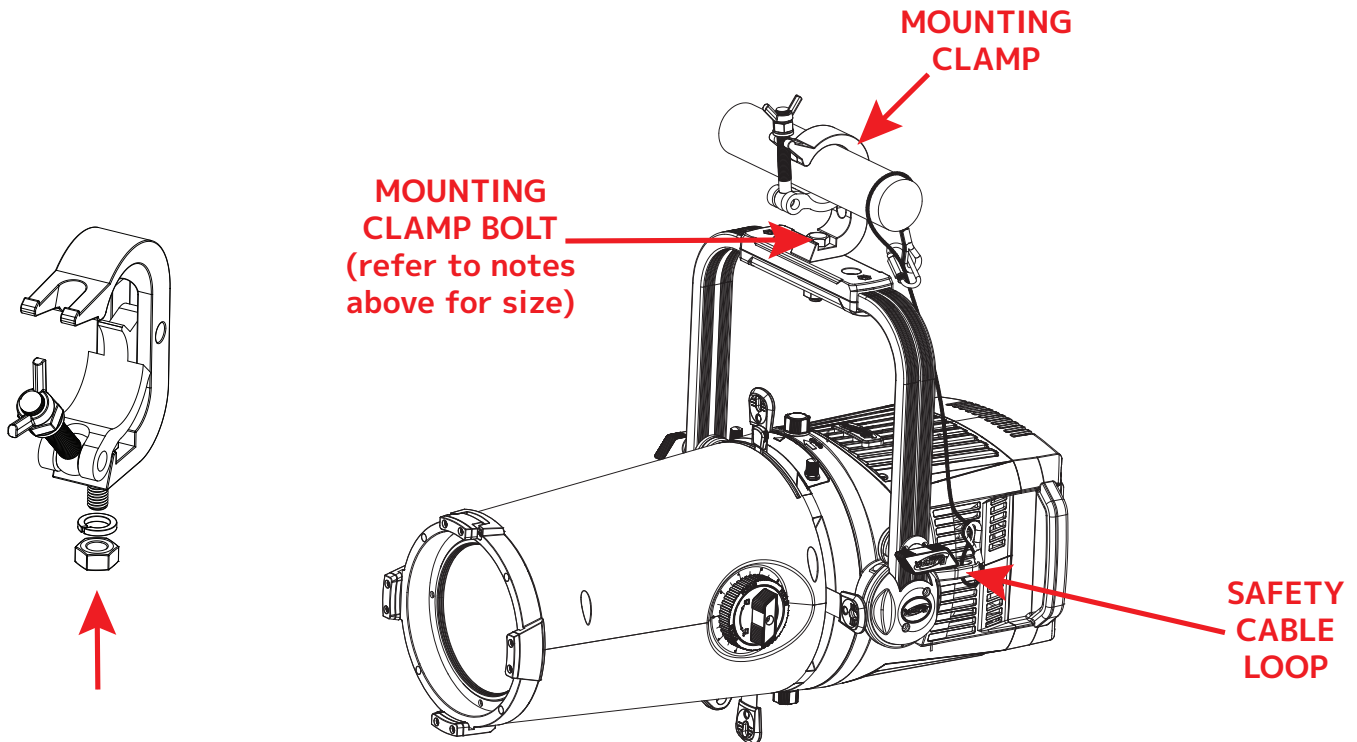

SAFETY CABLE:
ALWAYS ATTACH A SAFETY CABLE WHENEVER INSTALLING THIS FIXTURE IN A SUSPENDED ENVIRONMENT TO ENSURE THAT THE FIXTURE WILL NOT FALL IF THE CLAMP FAILS. ONLY USE DESIGNATED RIGGING POINTS FOR SAFETY CABLE, AND NEVER ATTACH A SAFELY CABLE TO A CARRYING HANDLE.

INSTALLATION GUIDELINES

RIGGING

Overhead rigging requires extensive experience, including calculating working load limits, installation material being used, and periodic safety inspection of all installation material and the fixture, among other skills. If you lack these qualifications, do not attempt the installation yourself. Improper installation can result in bodily injury.

The fixture is fully operational in the following positions: hanging from a horizontal truss, suspended sideways from a vertical truss, or standing upright on a flat, level surface. See the illustration below for reference.

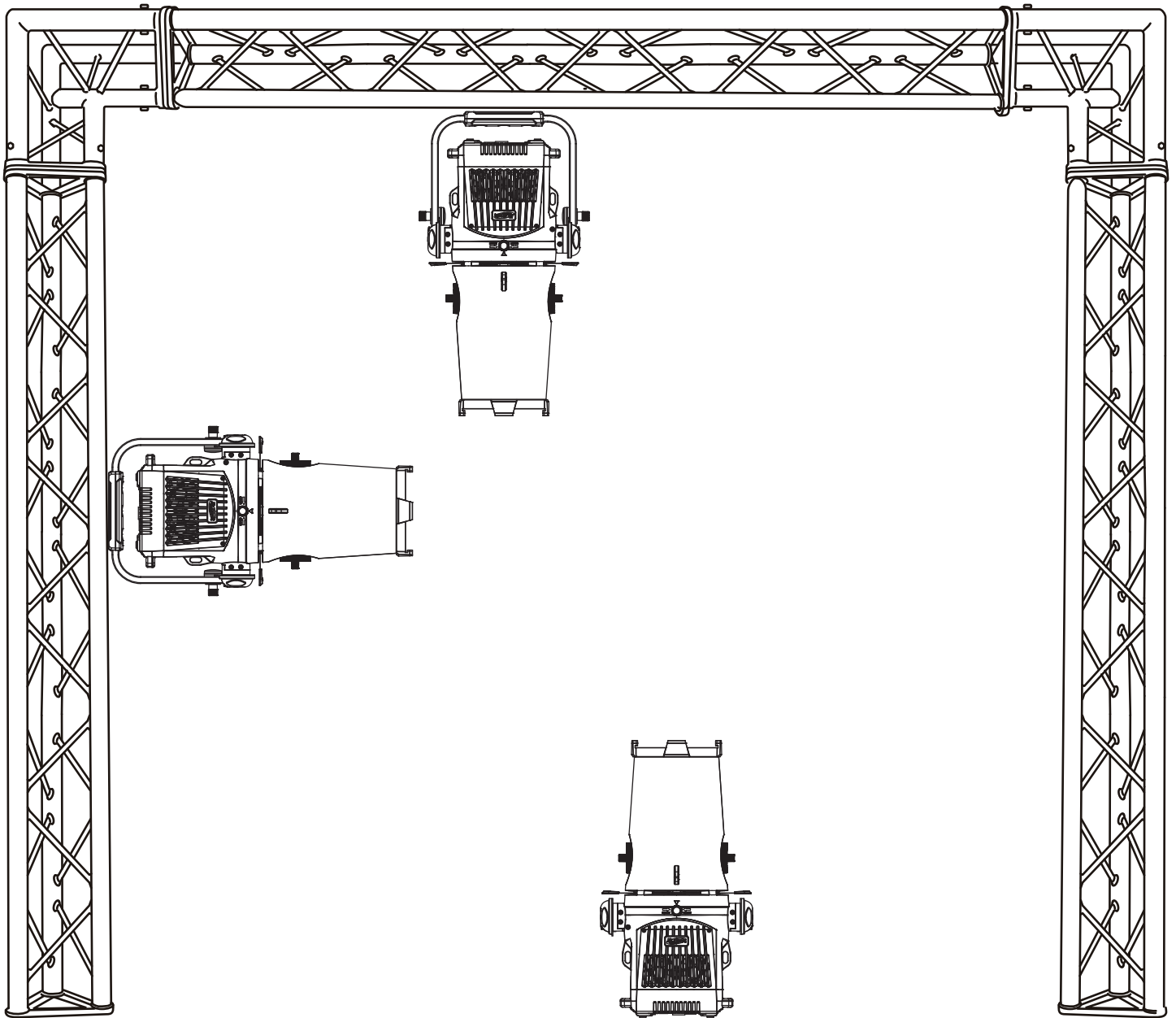

INSTALLATION GUIDELINES

POTENTIAL INTERNAL FIXTURE DAMAGE FROM EXTERNAL SOURCES OF LIGHT BEAMS

External sources of light beams from direct sunlight, lighting and moving head fixtures, and lasers, which are focused directly towards the exterior housing and/or penetrate the front lens opening of Elation lighting fixtures, can cause severe internal damage including burning of optics, dichroic color filters, glass and metal gobos, prisms, animation wheels, frost filters, iris, shutters, motors, belts, wiring, discharge lamps, and LEDs.

This issue is not specific only to Elation lighting fixtures, but rather it is a common issue with lighting fixtures from all manufacturers. Although there is no true way to fully prevent this issue from happening, the guidelines below can reduce the risk of potential damage. Contact Elation Service for more details.

DO NOT EXPOSE THE FIXTURE AND/OR FRONT LENS OPENING TO LIGHT BEAMS FROM DIRECT SUNLIGHT, OTHER LIGHTING OR MOVING HEAD FIXTURES, AND LASERS DURING UNPACKING, INSTALLATION, USE, AND EXTENDED IDLE TIMES OUTDOORS. DO NOT FOCUS A LIGHT BEAM FROM ONE LIGHTING FIXTURE DIRECTLY TOWARDS ANOTHER.

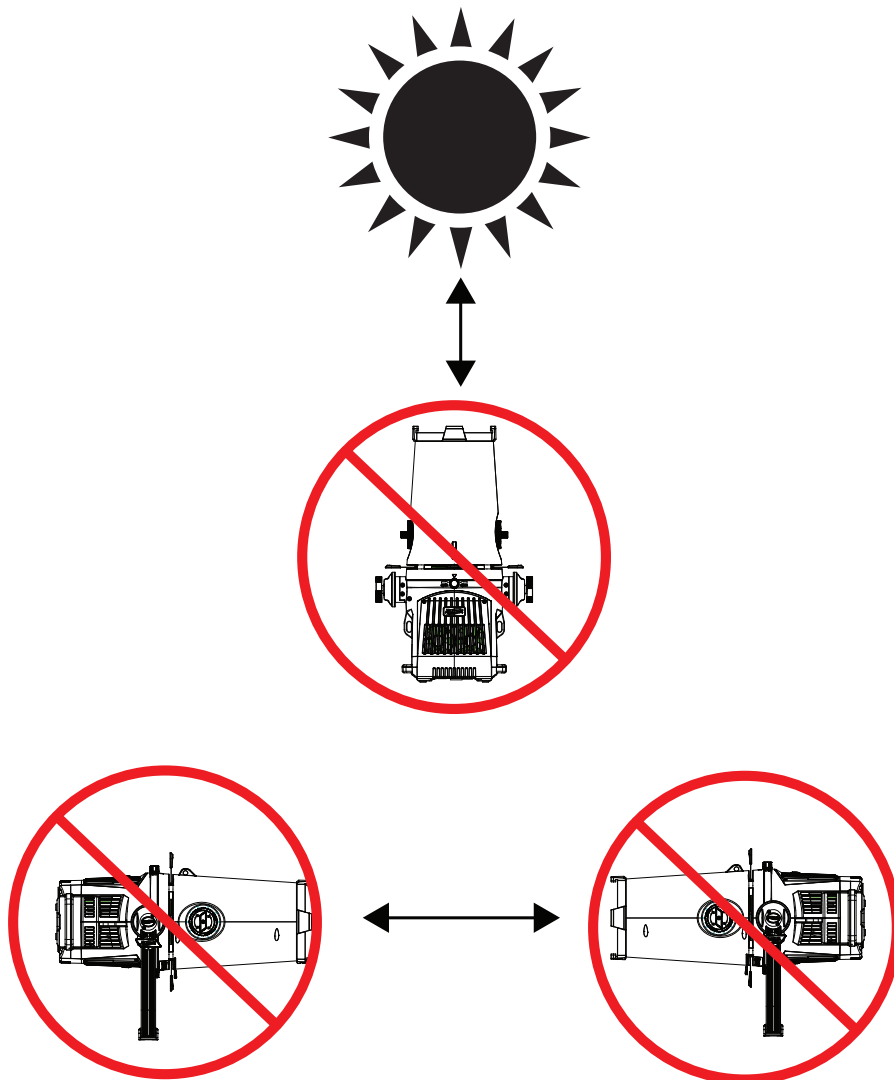

GOBOS: DESIGNER GOBO SET

This fixture includes a set of 10 uniquely-patterned glass gobos that can be used for a variety of show applications. Gobos should be stored in the included packaging when not installed in the fixture, and should only be handled by the edges. **Never touch the image surface on either side of the gobo!** A cloth is provided for cleaning purposes.

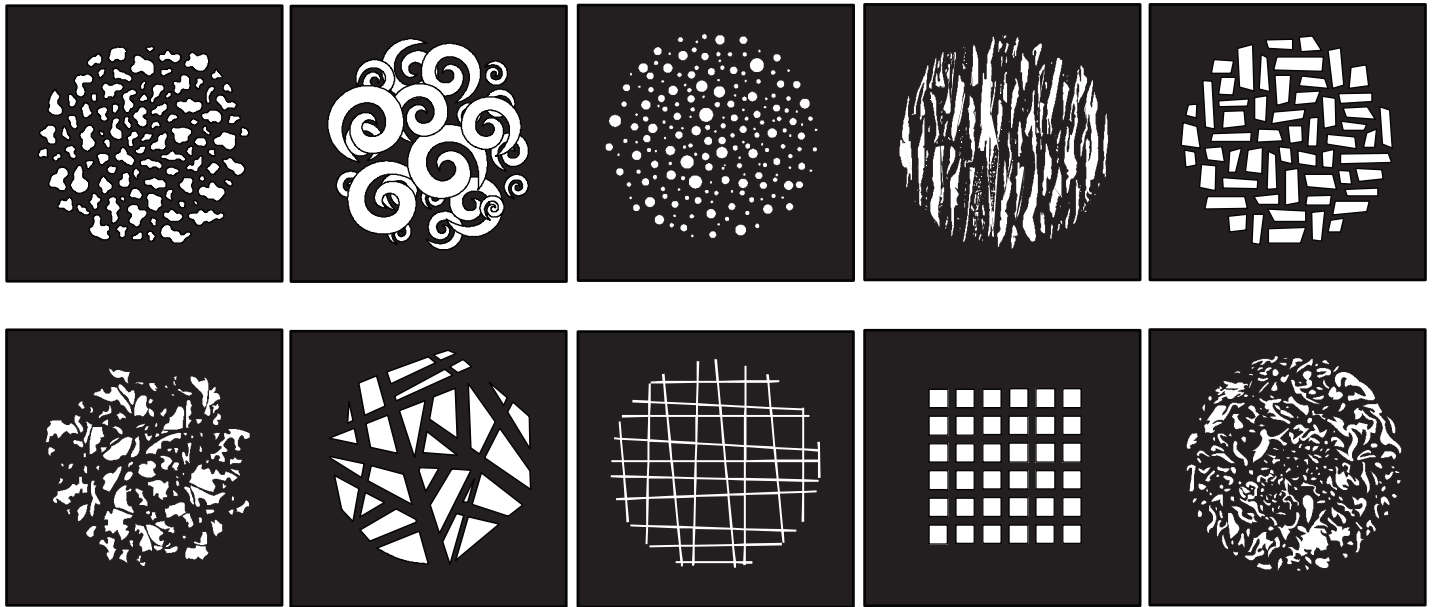

GOBOS

GOBO DIMENSIONS

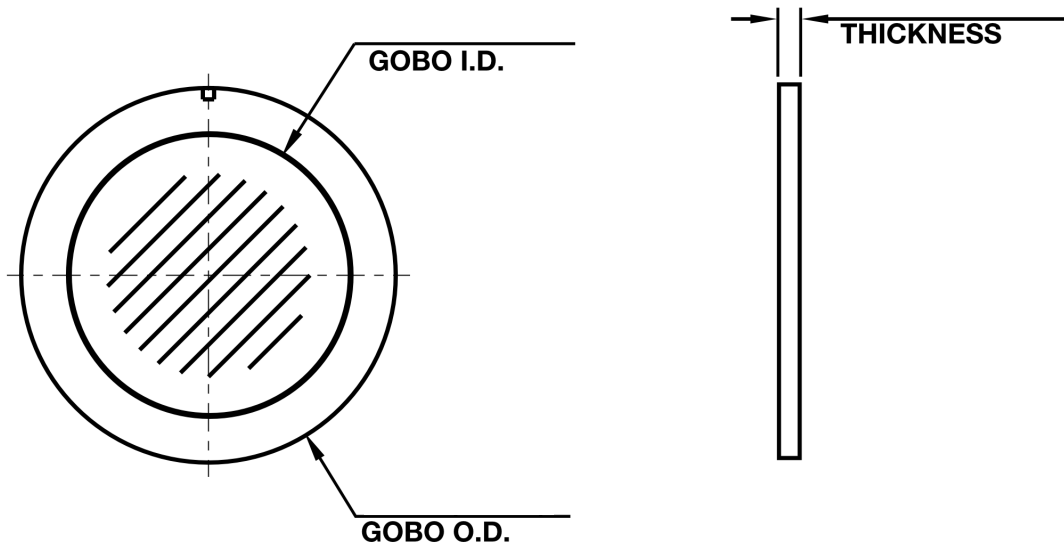

Gobo I.D	Gobo O.D.	Thickness
25mm	30mm ($_{-0.2}$)	1.1mm

Please note the following restrictions:

- The minimum temperature rating of the gobos is 850° F (450° C).
- The gobo must not have a broken or uneven edge, pinholes, scrapes in the coating, or other flaws, as these will seriously compromise the integrity of the gobo.
- Gobos are constructed out of metal or borofloat glass.

GOBOS

INSTALLATION

1. Switch the fixture off and allow at least 15 minutes for the fixture to cool. Use safety gloves to protect your hands, as well. Unscrew the fast lock screws, then remove the gobo access panel and carefully remove the gobo holder.

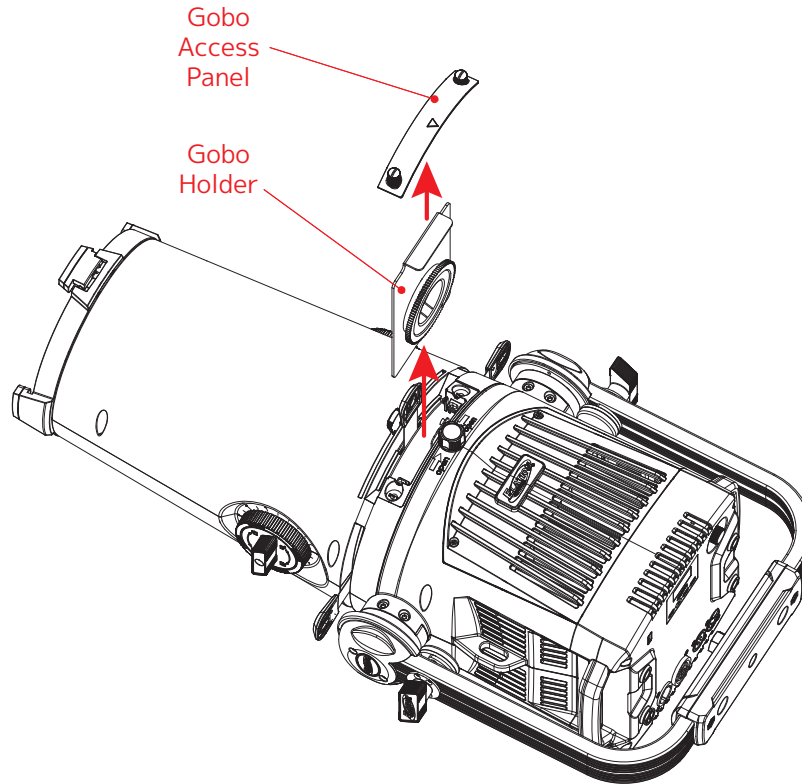

2. Release the gobo retainer by pressing on its release tab, then remove the gobo retainer, pressing plate, and the gobo. Install the new gobo with the silver plating on the same side as the gobo holder's rotating gear (the silver plating should face towards the rear of the fixture when the holder is installed), and align the mark on the gobo with the mark on the gobo holder. Secure the gobo in place by reinstalling the pressing plate and the gobo retainer.

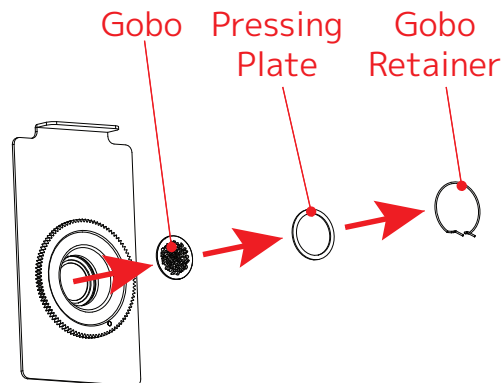

3. Insert the gobo holder into the gobo slot, then replace the gobo access panel and secure it in place by tightening the fast lock screws.

ACCESSORY INSTALLATION

LENS REPLACEMENT

The fixture can be fitted with multiple types of lenses. Follow the guidelines below to remove or install a lens.

1. Switch the fixture off and allow at least 15 minutes for the fixture to cool. Unscrew the four (4) screws located around the rim of the lens.
2. Remove the screws. The lens can now be removed.

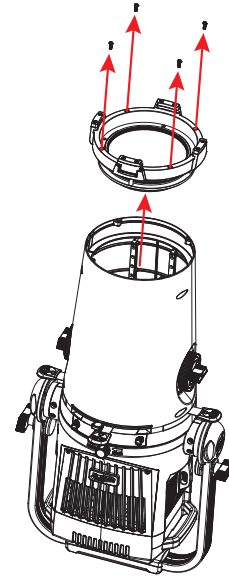
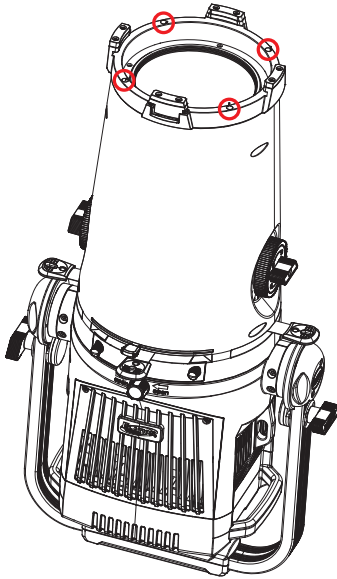

3. Install the new lens in place, then replace and tighten the four (4) screws located around the rim of the lens.

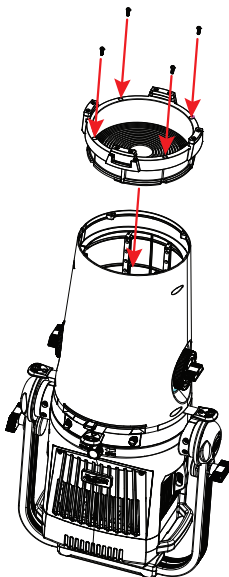

ZOOM AND FOCUS OPERATION

The zoom and focus functions of this unit are each operated manually by a pair of compound knobs located on the sides of the barrel. The first knob (shown below) controls the zoom function, while the second knob controls the focus, and each two-piece knob is labeled accordingly.

Each compound knob consists of an outer dial and an inner rotary switch. The dial is used to adjust the zoom or focus, while the rotary switch is used to lock or unlock the adjustment dial. Please note that the dial cannot be adjusted when the rotary switch is in the locked position. Each large dial has a slip brake to prevent slipping during normal usage. The rotary lock switch can be engaged to ensure against inadvertent operation, but its usage is not strictly required.

**DIAL ADJUSTS
ZOOM OR FOCUS**

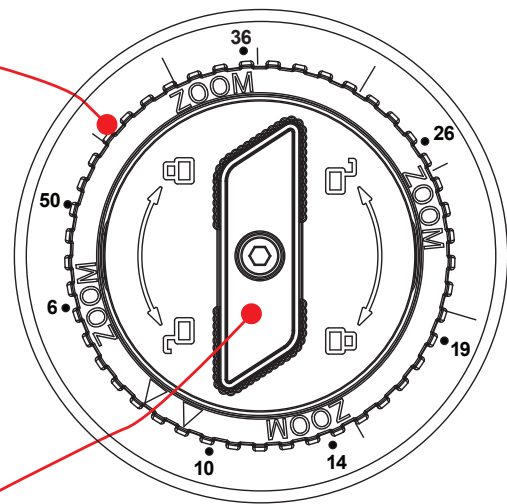

**ROTARY SWITCH
LOCKS OR
UNLOCKS DIAL**

It should also be noted that the Zoom dial includes markers to aid in the easy selection of commonly used beam angles. To do so, simply set the dial to one of the following beam angles: 6° - 10° - 14° - 19° - 26° - 36° - 50°

FRAMING OPERATION

The KL Profile FC features four adjustable framing blades.

Set the Zoom angle using the knob on the right side of the fixture (when fixture is oriented upright and viewed from the back) to adjust the light beam to the desired size. It is always ideal to use the smallest possible zoom angle to achieve the greatest light output from the fixture. Once the zoom position has been set to project the desired size of the light beam, the frames can be used to create straight edges.

Insert the frames to shape the light beam as desired. Angle the frames left and right to create the desired shape. Moreover, the barrel can be adjusted to rotate the entire shape at once to achieve the desired orientation. See the **Barrel Rotation** section of this manual for detailed information.

The sharpness of the frame can be adjusted using the Focus Knob on the left side of the fixture (when the fixture is held upright and viewed from the back).

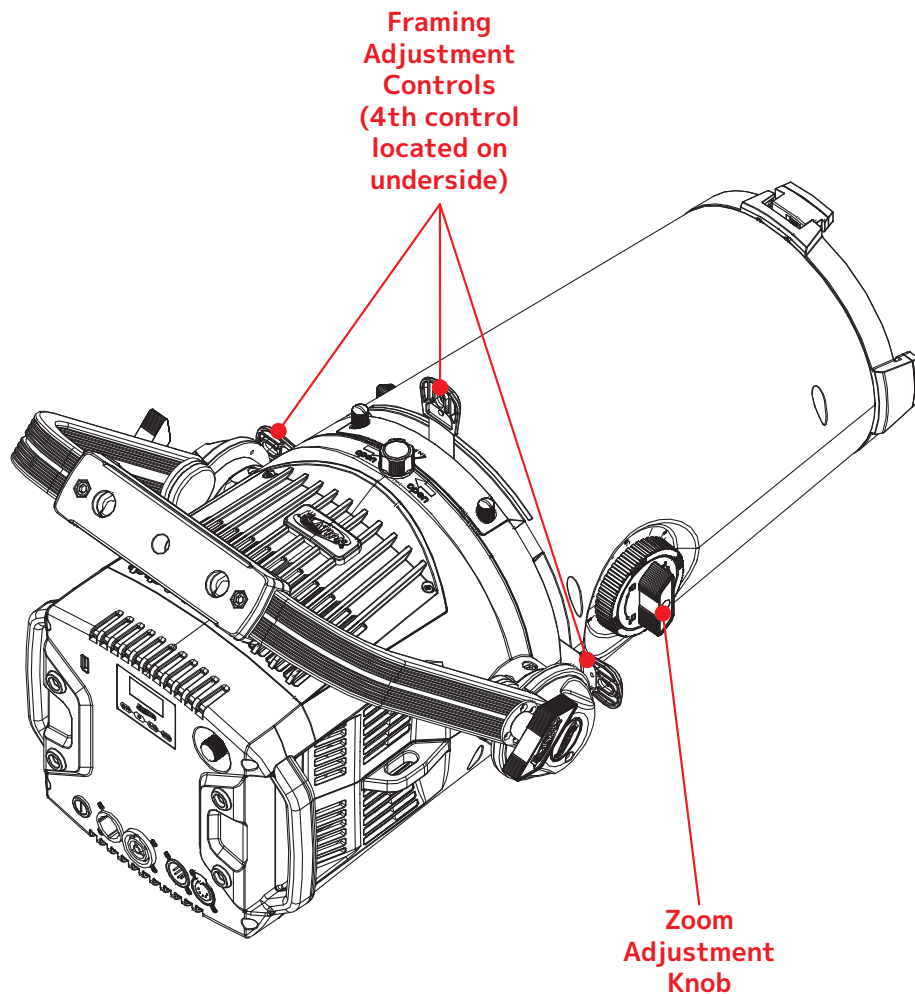

BARREL ROTATION

The lens barrel of this fixture can be rotated to adjust the framed shape, or removed for cleaning.

To rotate the lens barrel, loosen (but do not remove) the two screws located at the top and bottom of the barrel. The barrel should easily rotate by hand once these two screws have been loosened slightly, and it is not necessary to loosen the screws completely. Once the barrel has been rotated the desired amount, hand tighten the screws to secure the barrel in the desired position.

To remove the barrel, loosen the screws until they have reached their maximum open position. **Do NOT remove the screws completely.** Point the front of the fixture towards yourself and rotate the barrel with both hands approximately 90 degrees, until you are able to pull it free from the fixture body. Pull the barrel carefully off the fixture and remove any safety cable clips. Exercise caution, as the barrel is heavy. Place the barrel on a secure flat surface.

To reattach the barrel, align it to the grooves of the fixture housing, attach any safety clips, then slowly rotate the barrel until the arrows on the top of the barrel align with the arrows on the fixture. Secure the barrel by tightening the screws until they are hand tight.

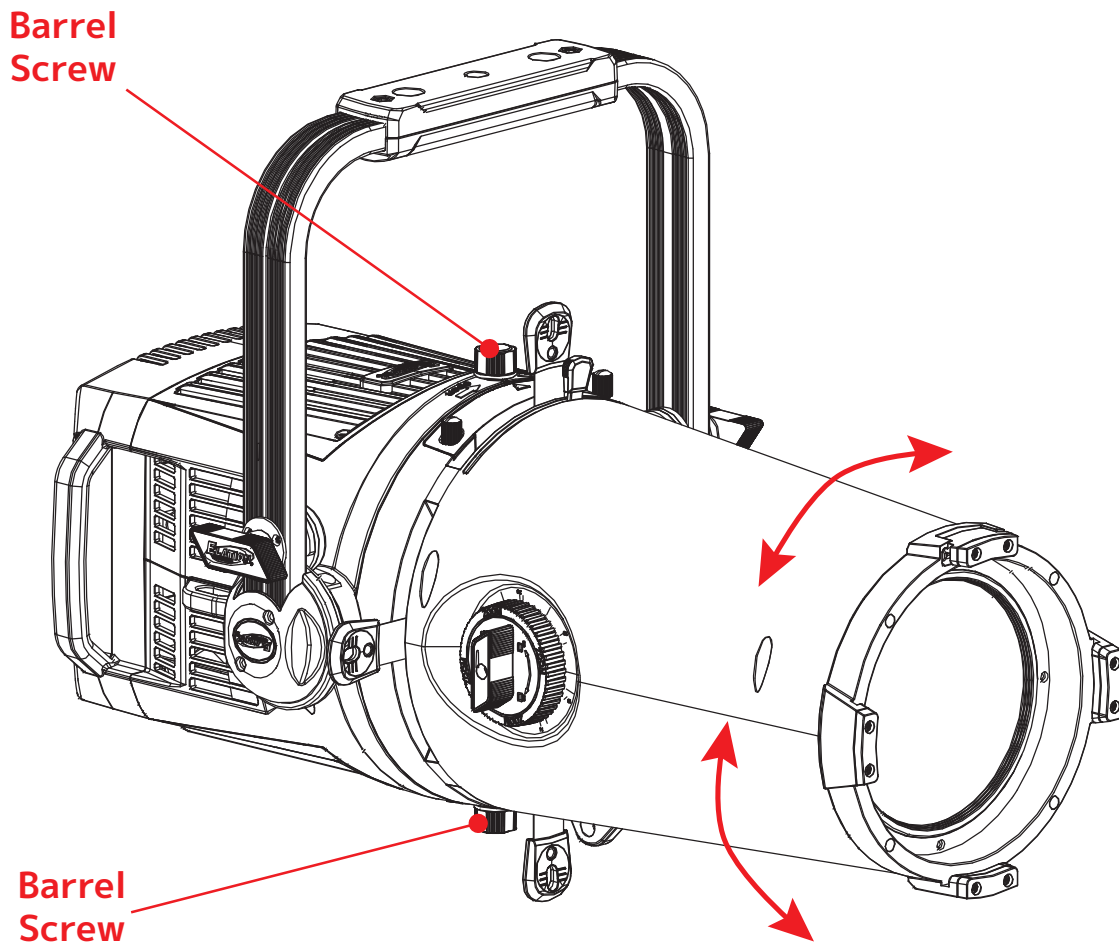

IRIS OPERATION

The integrated iris can be used in conjunction with the zoom control knob to adjust the size of the light beam. It can also be used to block off parts of a gobo image, if desired.

The iris handle is located near the framing adjustment handle on the top of the unit. Slide the iris handle carefully along its opening to make adjustments. The rubber handle provides for smooth operation and helps secure the Iris in place.

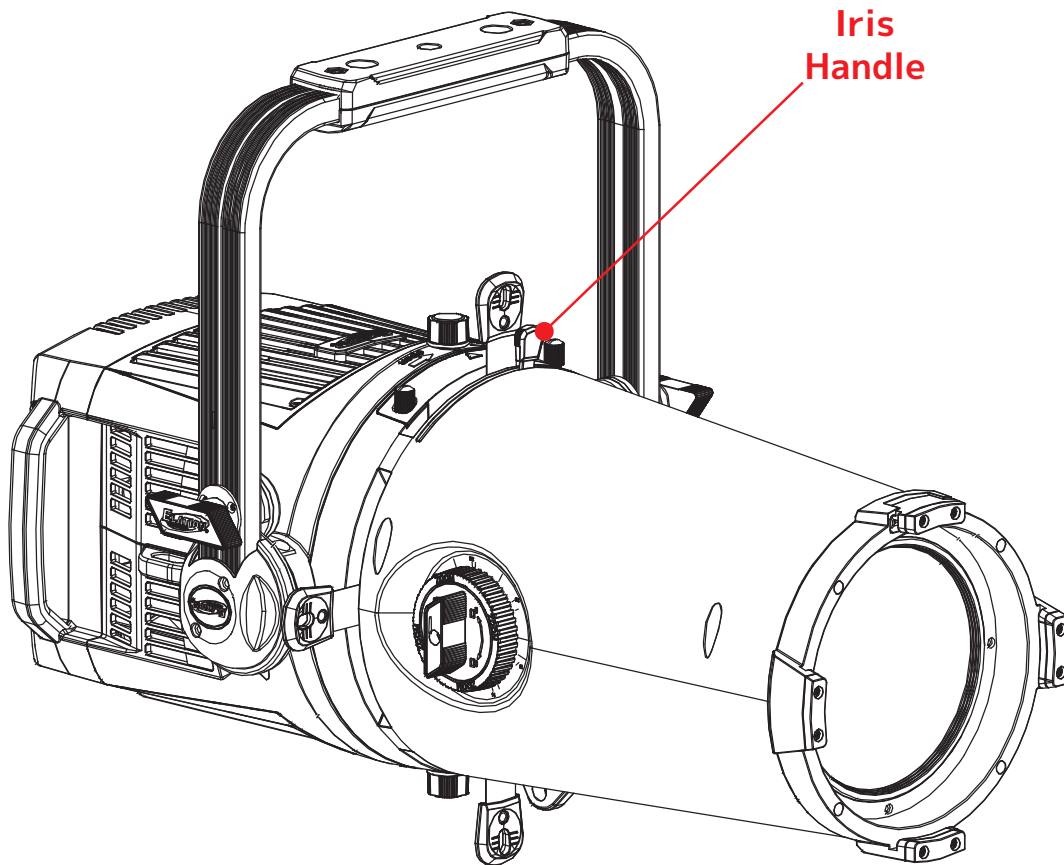

REMOTE DEVICE MANAGEMENT (RDM)

NOTE: In order for RDM to work properly, RDM enabled equipment must be used throughout the entire system, including DMX data splitters and wireless systems.

Remote Device Management (RDM) is a protocol that sits on top of the DMX512 data standard for lighting, allowing the DMX systems of the device to be managed, modified, and monitored remotely (hence, remote device management). This protocol is ideal for fixtures installed in locations that are not easily accessible.

With RDM, the DMX512 system becomes bi-directional, allowing a compatible RDM enabled controller to send out a signal to devices on the wire, as well as allowing the fixture to respond (known as a GET command). The controller can then use it's SET command to modify settings that would typically have to be changed or viewed directly via the unit's display screen, including the DMX Address, DMX Channel Mode, and Temperature Sensors.

FIXTURE RDM INFORMATION:

RDM Code	Device ID	Device Model ID	Personality ID
0x22A6	0029	41	001: Standard 002: Extend 003: CMY Standard 004: CMY Extended

Please be aware that not all RDM devices support all RDM features, and therefore it is important to check beforehand to ensure that the equipment that you are considering includes all of the features that you require.

The following parameters are accessible in RDM on this device:

[0x0200] Sensor Definition	[0x0500] Display Invert
[0x0201] Sensor Value	[0x0501] Display Level
[0x0080] Device Model Description	[0x0603] Realtime Clock
[0x0081] Manufacturer Label	[0x1010] Power State
[0x0082] Device Label	[0x1031] Preset Playback
[0x00E0] DMX Personality	[0x0120] Slot Information
[0x00E1] DMX Personality Description	[0x0121] Slot Description
[0x0400] Device Hours	[0x0122] Default Slot Value
[0x0015] Comms Status	[0x00B0] Language
[0x0031] Status ID Description	[0x00A0] Language Capabilites
[0x0032] Clear Status ID	[0x00C2] Boot Software Version Label
[0x0405] Device Power Cycles	[0x00C1] Boot Software Version ID
[0x0600] Pan Invert	[0x0070] Product Detail ID List
[0x0601] Tilt Invert	[0x0030] Status Messages
[0x0602] Pan Tilt Swap	

CONTROL PANEL

The fixture includes an easy to navigate system menu. The control panel display located on the side of the fixture (illustrated below) provides access to the main system menu where all necessary system adjustments are made to the fixture.

- During normal operation, pressing the **MODE** button once will access the fixture's main menu.
- Once in the main menu you can navigate through the different functions and access the sub-menus with the **DOWN** and **UP** buttons.
- Once you reach a field that requires adjusting, press the **ENTER** button to activate that field and use the **DOWN** and **UP** buttons to adjust the field.
- Pressing the **ENTER** button once more will confirm the setting.
- Exit the main menu at any time without making any adjustments by pressing the **MODE** button.

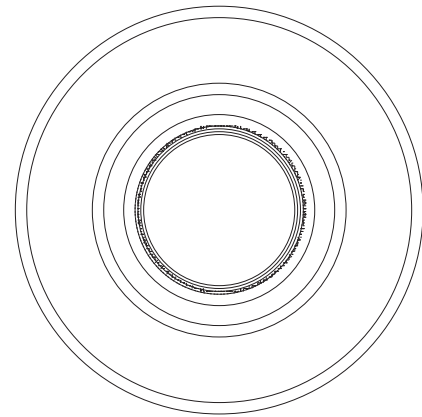
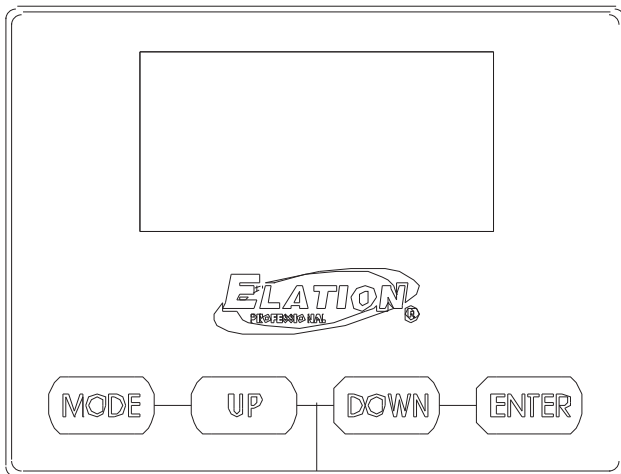

KEY LOCK

- **ON:** The screen will lock after a certain period of inactivity. To unlock the screen, press and hold the **MODE** button for 3 seconds.
- **OFF:** The screen will remain unlocked.
- **ON1:** The screen will lock after a certain period of inactivity. To unlock the screen, enter the unlock sequence **UP, DOWN, UP, DOWN, ENTER**.

ENCODER MODES

This device features an encoder knob located to the right of the display screen. This encoder knob can be used to manually adjust dimming, gobo rotation and indexing, CCT green shift, color saturation, or manual control. Press the button to cycle through parameters, and twist the knob to adjust the parameter currently displayed on the screen. Please see the **Encoder Mode** section of this manual for detailed information.

SYSTEM MENU

ELATION KL PROFILE FC SYSTEM MENU			
Supports Software Versions: 1.01			
Features subject to change without notice. Rotation direction (clockwise/counter-clockwise) and control of effects depend on head orientation and pan/tilt settings. Default settings listed in bold .			
ENCODER MODE	Disabled		See Encoder Modes section of this manual for detailed info
	Dimmer		
	INT Gobo		
	INT CCT GRN		
	INT CCT GRN GB		
	INT COLOR SAT		
	INT COLOR SAT GB		
	Manual Control		
DMX SETTINGS	DMX Address	001 - 512	
	DMX Mode	1CH Intensity	
		5CH Compact	
		12CH Standard	
		21CH Extended	
		10CH CMY	
		17CH CMY Ex	
		10CH RGB	
		17CH RGB Ex	
	No DMX Status	Hold Last	
Fade to Black		Unit fades to black if DMX signal lost	
Standalone		Unit defaults to standalone mode if DMX signal lost	
STANDALONE	Dimmer	000% to 100%	
	CCT	2400K to 8500K Default = 6000K	
	Green Shift	-100% to +100% Default = 0%	
	Virtual Color	See Virtual Color Table section of this manual	
	Gobo		
PERSONALITY	Primary	On / Off	
	Secondary	On / Off	
	Dim Modes	Standard	
		Stage	
		TV	
		Architectural	
		Theatre	
		Stage 2	
Dim Speed	0s - 10s	Default = 0.1s	

SYSTEM MENU

PERSONALITY (continued)	Dim Curves	Linear		
		Square		
		Square Inverse		
		S-Curve		
	E-Fly Setting	Set Channel		00 - 14
		Enable E-Fly		Yes / No
	LED Refresh Rate	900Hz - 1500Hz, 2500Hz, 4000Hz, 5000Hz, 6000Hz, 10KHz, 15KHz, 20KHz, 25KHz		Default = 1200Hz
	LED Power Limit	50%		
		60%		
		70%		
		80%		
		90%		
		100%		
	Fan Mode	Auto		
		High		
		Low		
		Studio		
		Mute		
	Display	Screen Delay	10s - 5min	Default = 1min
		Screen Lock	Off , 10s - 5min	
		Rotate Display	Yes	
			No	
	Service Passcode = 050	Calibration	Red 000 - 255	
Green 000 - 255				
Blue 000 - 255				
Mint 000 - 255				
Amber 000 - 255				
Update Software		On / Off		
Factory Restore		Yes / No		
INFORMATION	Life Time			
	Last Run Times			
	Time Reset	Passcode = 038		
	Temperature	Current		
		Max Resettable		
		Reset	Passcode = 038	
	DMX Values	Red		
		Green		
		...		
	Product IDs	RDM UID		
	Error Logs	Fixture Errors		
Reset Error Log		Yes / No	Passcode = 050	
Software Version				

E-FLY CONTROL



BEFORE SETTING THE WIRELESS CHANNEL ON ANY E-FLY FIXTURE, MAKE SURE THE SOURCE E-FLY WIRELESS DMX TRANSCEIVER DEVICE IS OFF.

TO CONTROL FIXTURE WITH E-FLY WIRELESS DMX SIGNAL

1. Ensure the source **E-FLY** wireless DMX Transceiver device is powered **OFF**.
2. Power **ON** fixture and from the LCD control panel select **DMX & E-FLY** or **E-FLY & OUT** in the **Select Signal** sub menu of the **PERSONALITY** main system menu.
3. From the LCD control panel set the **E-FLY** wireless channel to the same wireless channel of the source **E-FLY DMX** Transceiver device in the **Set E-FLY Chn** sub menu of the **PERSONALITY** main system menu.

NOTE: Erratic fixture movement may occur if other **E-FLY** wireless DMX products are in use in the same area and are using the same **E-FLY** wireless channel. The fixture may immediately start to respond to the DMX wireless signal from another **E-FLY** wireless DMX Transceiver immediately when **E-FLY** is enabled. Make sure to know what **E-FLY** wireless channels are being used in the area where the fixture is being installed.

RELATION E-FLY WIRELESS TRANSCEIVER only has 0-14 wireless channels, NO CH 15.

4. Set fixture DMX address in the **Set Dmx Address** sub menu of the **FUNCTION** main system menu.
5. The **E-FLY** signal Indicator on the fixture LCD control display will illuminate **GREEN** if a successful wireless DMX connection has been made or illuminate **RED** for NO connection. If no connection is made, repeat steps 1-4 above.
6. Repeat this process for all **E-FLY** compatible fixtures in the E-FLY wireless network, making sure all fixtures are assigned the same **E-FLY** wireless channel.
7. After all fixtures in the **E-FLY** wireless network have been set to the same **E-FLY** wireless channel and powered ON, now power ON the source **E-FLY** DMX Transceiver device.
8. Test all fixtures connected to the **E-FLY** wireless network to confirm proper functionality.

E-FLY CONTROL

WIRELESS WIFLY INSTALLATION LOCATION GUIDELINES

Wireless DMX signal can penetrate walls, glass, metal, and most other objects, but there are many factors, that can affect and/or interrupt the wireless DMX signal. One notable example is a person standing in the path of the signal. Therefore, it is highly recommended to position the wireless antenna a minimum of 9.8 ft. (3m) above audiences and/or above ground level. Careful planning and testing of the selected installation location is critical to ensure optimum and reliable wireless DMX operation.

**9.8 ft (3m)
Above Ground**

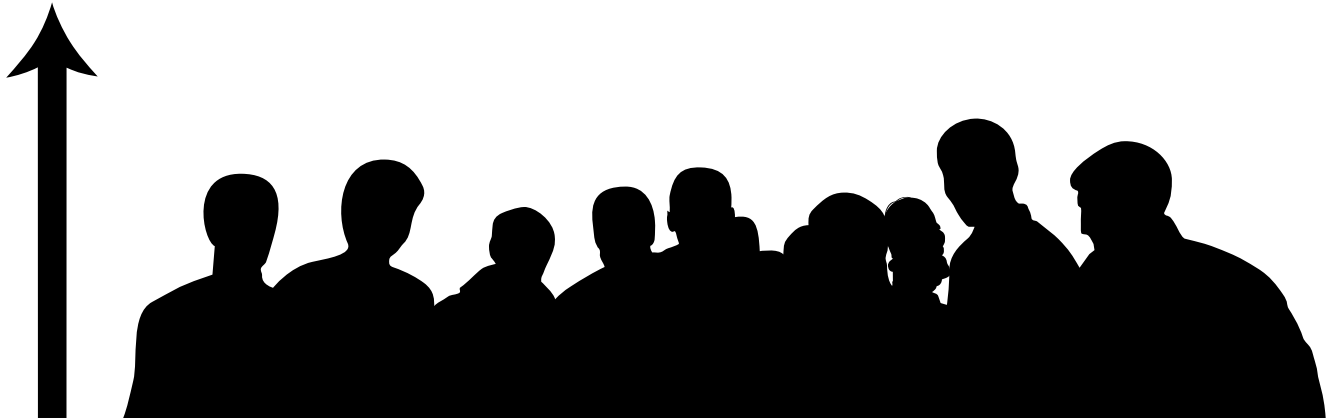

FAN CONTROL AND LOW NOISE OPERATION

This fixture is a high-performance fixture suited for many applications. For noise critical environments like Theater, Opera or Orchestra Halls, it offers various operation modes to remove any distraction for the audience and performers. Modes can be changed remotely via the DMX control channel, allowing the fixture to offer high output or whisper silent operation at a moment's notice. All modes smoothly transition over a brief period, preventing unwanted attraction to the fixture.

Mode	dbA at 1m LED off	dbA at 1m Dimmer 100%
Ambient Noise Level 31 dbA		
Fan Control - Auto (Default)	TBD	TBD
Fan Control - Low	TBD	TBD
Fan Control - High	TBD	TBD
Low Noise - Mute	TBD	TBD
Low Noise - Studio	TBD	TBD

Fan Modes

Auto – The default AUTO mode ensures optimal performance of the fixture. Fans only run at the speeds needed to keep the LED engine within a safe temperature range. They will turn off if possible, for example when the fixture is dimmed to a low intensity. Fans sense the ambient and fixture temperature, and will at all times try to keep noise levels at a minimum. The fixture output will only reduce when the LED engine cannot be cooled down to its safe operating range due to high ambient temperature. **Auto is the recommend mode for daily operation.**

Low – In this mode the fixture reduces fan speeds throughout for a lower noise profile of the fixture. This mode should be sufficient for most uses where lower noise is required. The fixture output is reduced to about 80%.

High – This mode is only required in very high ambient temperatures when automatic fan speed adjustments are not desired. High Fan Speed will cool the fixture most efficiently. This mode will increase wear on the fans and should only be utilized in exceptional circumstances. Fans will always run, even if the fixture is dimmed. Fixture output is kept at 100% unless the LED engine temperature is too high, at which point the fixture will reduce power carefully to ensure safe operation.

Low Noise Modes

For very critical situations, this unit offers two additional low noise modes for silent operation. The fixture output will be reduced, but as the fixture has such an extremely high luminous flux, it still offers outstanding performance. In low noise modes, all parameters of the fixture operate quieter and with reduced speeds.

Studio – This mode reduces the fixture output to approximately 50%. Almost all fans inside the fixture are turned off, and only run when absolutely necessary to keep the fixture at 50% LED power.

Mute – Running the fixture in MUTE mode reduces the fixture to about 25% output, and all fans are off. The fixture is totally silent.

ENCODER MODES

MODE	PARAMETER	VALUES	RESOLUTION	DEFAULT
DIMMER	Intensity	0% to 100%	1%	0%
INT GOBO	Intensity	0% to 100%	1%	0%
	Gobo	Indexing: 0 degrees to 360 degrees	1 degree	180 degrees
		Clockwise rotation, fast to slow	%	
		Rotation Stop	Stop	
Counter-clockwise rotation, slow to fast	%			
INT CCT GRN	Intensity	0% to 100%	1%	0%
	CCT	2400K to 8500K	100K	6000K
	Green Shift	GRN -100% to +100%	1%	Neutral (0%)
INT CCT GRN GB	Intensity	0% to 100%	1%	0%
	CCT	2400K to 8500K	100K	6000K
	Green Shift	GRN -100% to +100%	1%	Neutral (0%)
	Gobo	Indexing: 0 degrees to 360 degrees	1 degree	180 degrees
Clockwise rotation, fast to slow		%		
Rotation Stop		Stop		
Counter-clockwise rotation, slow to fast	%			
INT COLOR SAT	Intensity	0% to 100%	1%	0%
	Color	Virtual Color 1, 2, 3...	Single Color	
	Saturation	Sat 0% to 100%	1%	100%
INT COLOR SAT GB	Intensity	0% to 100%	1%	0%
	Color	Virtual Color 1, 2, 3...	Single Color	
	Saturation	Sat 0% to 100%	1%	100%
	Gobo	Indexing: 0 degrees to 360 degrees	1 degree	180 degrees
Clockwise rotation, fast to slow		%		
Rotation Stop		Stop		
Counter-clockwise rotation, slow to fast	%			
MANUAL CONTROL	Intensity	0% to 100%	1%	0%
	Strobe	Open	-	Open
		Slow to Fast	1%	
		Pulse Slow to Fast	1%	
		Random Slow to Fast	1%	
	Red	0% to 100%	1%	0%
	Green	0% to 100%	1%	0%
	Blue	0% to 100%	1%	0%
	Mint	0% to 100%	1%	0%
Amber	0% to 100%	1%	0%	

DMX TRAITS

ELATION KL PROFILE FC DMX CHANNEL TRAITS												
Supports Software Versions: 1.0.1												
Features subject to change without notice. Rotation direction (clockwise/counter-clockwise) and control of effects depends on head orientation and pan/tilt settings.												
CHANNEL								DMX VALUES	FUNCTION	Default	Snap	
Inten.	Comp	Std	Ext	CMY	CMY Ext	RGB	RGB Ext					
				1	1			000 - 255	Cyan , 0% to 100%	000		
					2			000 - 255	Cyan Fine , 0% to 100%	000		
				2	3			000 - 255	Magenta , 0% to 100%	000		
					4			000 - 255	Magenta Fine , 0% to 100%	000		
				3	5			000 - 255	Yellow , 0% to 100%	000		
					6			000 - 255	Yellow Fine , 0% to 100%	000		
		1	1			1	1	000 - 255	Red , 0% to 100%	255		
			2				2	000 - 255	Red Fine , 0% to 100%	255		
		2	3			2	3	000 - 255	Green , 0% to 100%	255		
			4				4	000 - 255	Green Fine , 0% to 100%	255		
		3	5			3	5	000 - 255	Blue , 0% to 100%	255		
			6				6	000 - 255	Blue Fine , 0% to 100%	255		
		4	7					000 - 255	Mint , 0% to 100%	255		
			8					000 - 255	Mint Fine , 0% to 100%	255		
		5	9					000 - 255	Amber , 0% to 100%	255		
			10					000 - 255	Amber Fine , 0% to 100%	255		
									CTO			
	1	6	11	4	7	4	7	000 - 023	Open	000		
								024 - 085	CTO 2400K - 8500K, see CTO Table section of this manual			
								086 - 255	8500K			
									Color Wheel			
								000	Open	000		
								001 - 053	Virtual Swatch Book, see Virtual Colors Table section of this manual			
								054 - 179	Open			
									Color Scroll			
								180 - 201	Clockwise, fast to slow			
								202 - 207	Stop			
								208 - 229	Counter-Clockwise, slow to fast			
								230 - 234	Open			
									Random Slots			
								235 - 239	Fast			
								240 - 244	Medium			
								245 - 249	Slow			
								250 - 255	Open			

DMX TRAITS

CHANNEL								DMX VALUES	FUNCTION	Default	Snap
Inten.	Comp	Std	Ext	CMY	CMY Ext	RGB	RGB Ext				
			13		9		9		Green Shift	000	
								000	Idle		
								001 - 127	Full Minus Green to Neutral		
								128	Neutral White		
								129 - 255	Neutral to Full Plus Green		
			14		10		10		CTC Crossfade	000	
								000	CTC		
								001 - 254	No function		
								255	Color Mix		
	2	8	15	6	11	6	11		Gobo Index and Rotation	063	
								000 - 127	Gobo Indexing		
								128 - 189	Clockwise gobo rotation, fast to slow		
								190 - 193	No rotation		
								194 - 255	Counter-clockwise gobo rotation, slow to fast		
	3		16		12		12	000 - 255	Gobo Fine Indexing	000	
									Shutter, Strobe	050	
								000 - 031	Shutter closed		
								032 - 063	No function (shutter open)		
								064 - 095	Strobe effect, slow to fast		
		9	17	7	13	7	13	096 - 127	No function (shutter open)		
								128 - 159	Pulse effect in sequences		
								160 - 191	No function (shutter open)		
								192 - 223	Random strobe effect, slow to fast		
								224 - 255	No function (shutter open)		
1	4	10	18	8	14	8	14	000 - 255	Dimmer Intensity, 0% to 100%	000	
	5	11	19	9	15	9	15	000 - 255	Dimmer Fine	000	
									Dim Modes	000	
								000 - 020	Standard		
								021 - 040	Stage		
			20		16		16	041 - 060	TV		
								061 - 080	Architectural		
								081 - 100	Theatre		
								101 - 120	Stage 2		

DMX TRAITS

CHANNEL								DMX VALUES	FUNCTION	Default	Snap
Inten.	Comp	Std	Ext	CMY	CMY Ext	RGB	RGB Ext				
			20		16		16		Dimmer Delay Time	000	
								121	0s		
								122	0.1s		
								123	0.2s		
								124	0.3s		
								125	0.4s		
								126	0.5s		
								127	0.6s		
								128	0.7s		
								129	0.8s		
								130	0.9s		
								131	1.0s		
								132	1.5s		
								133	2.0s		
								134	3.0s		
								135	4.0s		
								136	5.0s		
								137	6.0s		
								138	7.0s		
								139	8.0s		
								140	9.0s		
								141	10.0s		
								142 - 255	Idle		
									Control	000	X
								000 - 039	Idle		
								040 - 044	Fan Mode Studio		
								045 - 049	Fan Mode Mute		
								050 - 059	Fan Mode Low		
								060 - 069	Fan Mode High		
								070 - 079	Fan Mode Auto		
								080 - 084	Reset		
								085 - 099	Idle		
									Refresh Rate (Hz)		
		12	21	10	17	10	17	100	900		
								101	910		
								102	920		
								103	930		
								104	940		
								105	950		
								106	960		
								107	970		
								108	980		

DMX TRAITS

CHANNEL								DMX VALUES	FUNCTION	Default	Snap
Inten.	Comp	Std	Ext	CMY	CMY Ext	RGB	RGB Ext				
									Refresh Rate (Hz) (continued)		
								109	990		
								110	1000		
								111	1010		
								112	1020		
								113	1030		
								114	1040		
								115	1050		
								116	1060		
								117	1070		
								118	1080		
								119	1090		
								120	1100		
								121	1110		
								122	1120		
								123	1130		
								124	1140		
								125	1150		
								126	1160		
								127	1170		
		12	21	10	17	10	17	128	1180	000	X
								129	1190		
								130	1200		
								131	1210		
								132	1220		
								133	1230		
								134	1240		
								135	1250		
								136	1260		
								137	1270		
								138	1280		
								139	1290		
								140	1300		
								141	1310		
								142	1320		
								143	1330		
								144	1340		
								145	1350		
								146	1360		
								147	1370		
								148	1380		
								149	1390		

SYSTEM MENU

CHANNEL								DMX VALUES	FUNCTION	Default	Snap
Inten.	Comp	Std	Ext	CMY	CMY Ext	RGB	RGB Ext				
									Refresh Rate (Hz) (continued)		
								150	1400		
								151	1410		
								152	1420		
								153	1430		
								154	1440		
								155	1450		
								156	1460		
								157	1470		
								158	1480		
								159	1490		
								160	1500		
		12	21	10	17	10	17	161	2500	000	X
								162	4000		
								163	5000		
								164	6000		
								165	10000		
								166	15000		
								167	20000		
								168	25000		
								169 - 200	Idle		
								201 - 210	Dimmer Curve Linear		
								211 - 220	Dimmer Curve Square		
								221 - 230	Dimmer Curve Inverse Square		
								231 - 240	Dimmer Curve S-Curve (default)		
								241 - 255	Idle		

CTO TABLE

DMX VALUE	COLOR TEMP (K)	DMX VALUE	COLOR TEMP (K)
024	2400	055	5500
025	2500	056	5600
026	2600	057	5700
027	2700	058	5800
028	2800	059	5900
029	2900	060	6000
030	3000	061	6100
031	3100	062	6200
032	3200	063	6300
033	3300	064	6400
034	3400	065	6500
035	3500	066	6600
036	3600	067	6700
037	3700	068	6800
038	3800	069	6900
039	3900	070	7000
040	4000	071	7100
041	4100	072	7200
042	4200	073	7300
043	4300	074	7400
044	4400	075	7500
045	4500	076	7600
046	4600	077	7700
047	4700	078	7800
048	4800	079	7900
049	4900	080	8000
050	5000	081	8100
051	5100	082	8200
052	5200	083	8300
053	5300	084	8400
054	5400	085	8500

VIRTUAL COLORS TABLE

VALUE	FILTER #	COLOR	VALUE	FILTER #	COLOR
1	7	pale yellow	31	126	Mauve
2	103	straw	32	49	Medium Purple
3	151	gold tint	33	58	Lavender
4	100	spring yellow	34	199	Palace Blue
5	10	medium yellow	35	119	Dark Blue
6	101	yellow	36	132	Medium Blue
7	104	deep amber	37	120	Deep Blue
8	15	deep straw	38	165	Daylight Blue
9	179	loving amber	39	161	Slate Blue
10	21	gold amber	40	118	Light Blue
11	105	orange	41	68	Sky Blue
12	158	deep orange	42	143	Pale Navy Blue
13	22	dark amber	43	131	Marine Blue
14	778	millennium gold	44	115	Peacock Blue
15	135	deep golden amber	45	172	Lagoon Blue
16	24	scarlet	46	116	Medium Blue Green
17	106	primary red	47	90	Dark Yellow Green
18	26	bright red	48	139	Primary Green
19	27	medium red	49	122	Fern Green
20	19	fire	50	89	Moss Green
21	157	pink	51	124	Dark Green
22	36	medium pink	52	88	Lime Green
23	111	dark pink	53	138	Pale Green
24	128	bright pink	54-179		No Function
25	148	bright rose			
26	332	special rose pink			
27	793	vanity fair			
28	113	Magenta			
29	46	Dark Magenta			
30	48	Rose Purple			

DIMMER CURVES

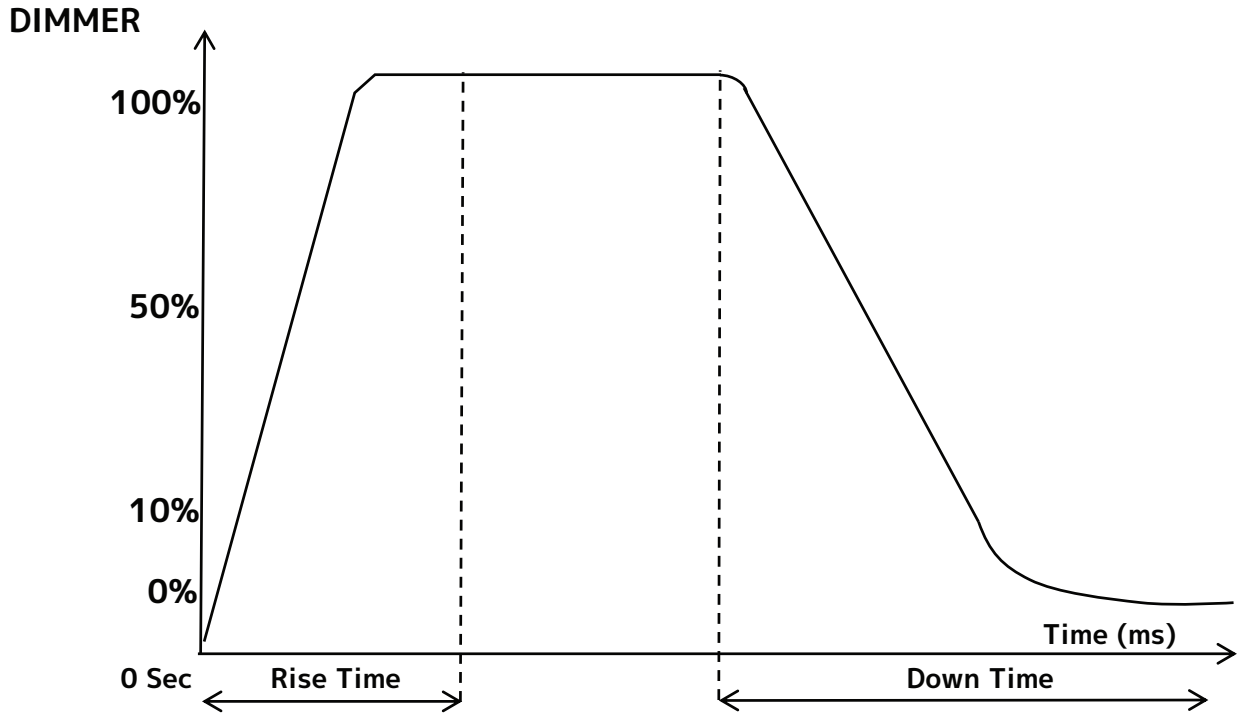

Dimming Curve Ramp Effect	0 sec Fade Time		1 sec Fade Time	
	Rise Time (ms)	Down Time (ms)	Rise Time (ms)	Down Time (ms)
Standard (default)	0	0	0	0
Stage	780	1100	1540	1660
TV	1180	1520	1860	1940
Architectural	1380	1730	2040	2120
Theatre	1580	1940	2230	2280
Stage 2	0	1100	0	1660

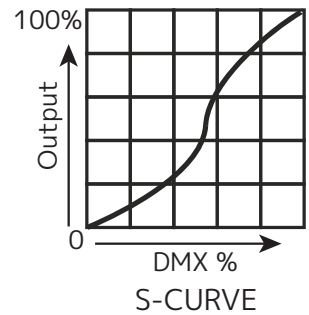
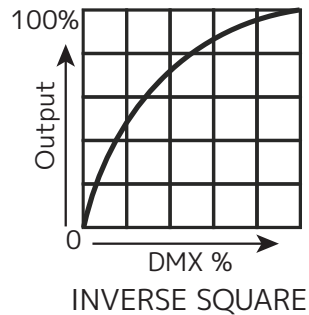
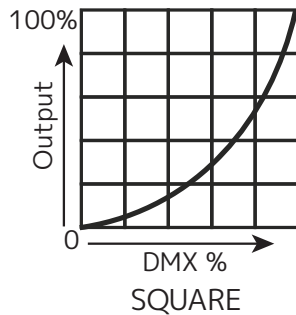
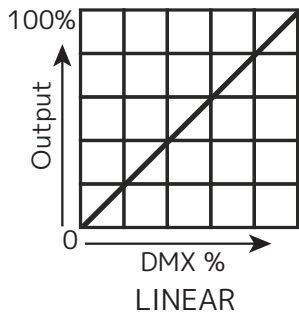

SOFTWARE UPDATES



ONLY QUALIFIED TECHNICIANS SHOULD PERFORM THIS FUNCTION!
NOTE ALL MENU SETTINGS BEFORE UPDATING SOFTWARE!
FIXTURE SOFTWARE CAN NOT BE DOWNGRADED!
DOWNLOAD FIXTURE SOFTWARE TO PC ONLY! (NO MAC SUPPORT)
PLEASE CONTACT ELATION SERVICE FOR FURTHER INFORMATION.

ELATION C-LOADER

An Elation C-Loader can be used to update the fixture to the latest software. Please visit the C-Loader product page at the Elation web site and download the product manual for step by step instructions.

<https://www.elationlighting.com/c-loader-software-uploader>

To order the C-Loader uploader and the updated software for your fixture, please contact Elation support for details.

STANDARD SERVICE PORT METHOD

1. Copy the updated software onto a USB memory stick.
2. Reset the fixture(s), then insert the USB memory stick directly into the service port of the fixture.
3. In the main menu, navigate to "Personality", then press ENTER.
4. Navigate to the "Service" sub-menu, then press ENTER.
5. Key in "050" for the password, then press ENTER again.
6. Scroll to the "Yes" option, and press ENTER.
7. Scroll to the desired software file and press ENTER.
8. Select "On" and press ENTER again. The software should now begin copying.

Note: Do NOT interrupt this process, and do NOT remove the USB memory stick until the update has been completed and the fixture has automatically reset and returned to the default menu. Failure to follow these guidelines may render your fixture inoperable.

AUTOMATIC SERVICE PORT METHOD - This method can be used when updating software for a single fixture. Does NOT work for updating multiple linked fixtures.

1. Copy updated software onto a USB memory stick.
2. Switch off power on the fixture, then plug the USB memory stick into the service port.
3. Power the fixture on. The data on the memory stick should automatically be detected.
4. Use the UP and DOWN buttons to select the desired software file and press ENTER.
5. Select "On" and press ENTER. The software should now begin copying.

Note: Do NOT interrupt this process, and do NOT remove the USB memory stick until the update has been completed and the fixture has automatically reset and returned to the default menu. Failure to follow these guidelines may render your fixture inoperable.

ERROR CODES

ERROR CODE	DESCRIPTION
Fan Error	These messages will appear if there is a fan and/or temperature malfunction.
Temp Error	

Note: Error Codes are subject to change without notice.

SPECIFICATIONS

SOURCE

305W 6,500K RGBMA LED Engine

30,000 Hour Average LED Life*

*Test lab conditions. May vary depending on several factors including but not limited to: Environmental Conditions, Power/Voltage, Usage Patterns (On-Off Cycling), Control, and Dimming.

PHOTOMETRIC DATA

10,600 Total Lumen Output

CRI 93.5

Zoom Range 6° - 50°

Beam Angle 5.9° - 45.6°

Field Angle 6.6° - 50°

EFFECTS

Manual Locking Zoom, Focus

4 Manual Rotating Full Blackout Framing Blades

Manual Barrel Rotation

Integrated Manual Iris

Variable 16-bit Dimming Curve

COLOR

RGBMA Color Array

CMY and RGB Emulation

Variable CCT 2400K - 8500K

Green/Magenta Shift

Virtual Gel Swatch Book

GOBOS

1x 16bit Rotating / Indexing Interchangeable Glass Gobo

CONTROL / CONNECTIONS

8 DMX Channel Modes (1/5/12/21) CMY(10/17) RGB(10/17)

DMX Adjustable LED Frequency

DMX, RDM Protocol Support

4 Button Touch Control Panel

Encoder Control for Standalone Operation

Full Color 180° Reversible LCD Menu Display

5pin DMX In/Out

IP65 Locking Power In/Out

Elation's E-FLY™ Internal Wireless DMX Transceiver

SIZE / WEIGHT

Length: 25.1" (637.6mm)

Length (Yoke 0°): 27.6" (701.0mm)

Width: 15.4" (390mm)

Height: 13.6" (345.0mm)

Height (Fixture Body): 11.0" (279.0mm)

Height (Yoke 90°): 18.4" (466.5mm)

Weight: 35.2lbs (15.9kg)

7.5" Front Accessory Slot

ELECTRICAL / THERMAL

AC 100-240V - 50/60Hz

358W Max Power Consumption

14°F to 113°F (-10°C to 45°C)

BTU/hr (+/- 10%) 1124.1

OPTIONAL ACCESSORIES

#8050000053 - Omega Bracket

APPROVALS / RATINGS

CE | cETLus | IP20

Specifications and documentation subject to change without notice.

DIMENSIONS

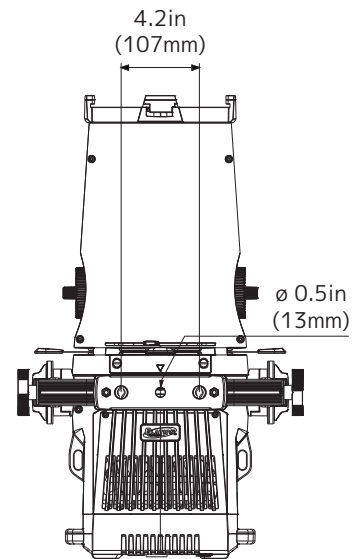
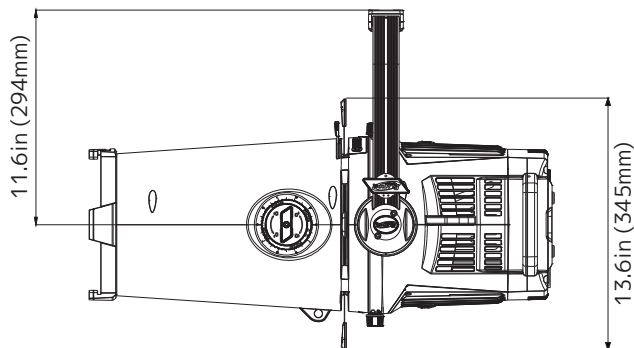
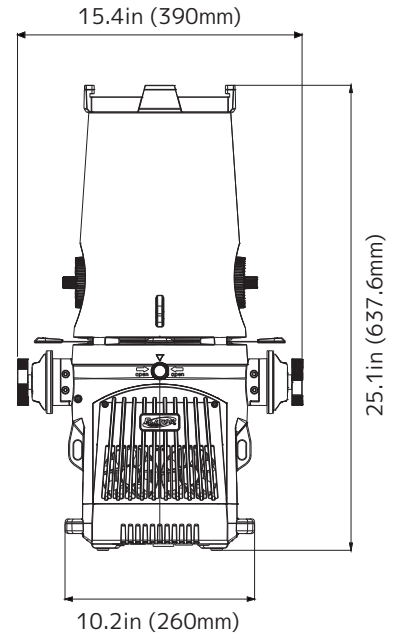
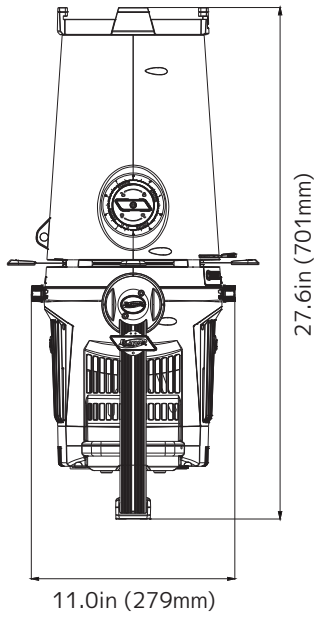
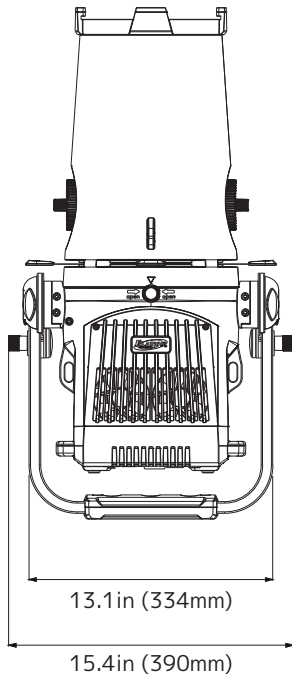
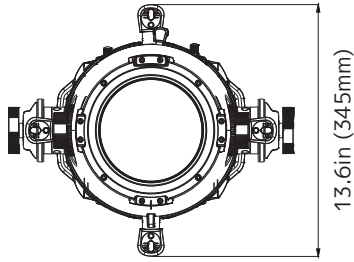

FCC STATEMENT

This device complies with Part 15 of the FCC Rules. Operation is subject to the following two conditions: (1) this device may not cause harmful interference, and (2) this device must accept any interference received, including interference that may cause undesired operation.

FCC RADIO FREQUENCY INTERFERENCE WARNINGS & INSTRUCTIONS

This product has been tested and found to comply with the limits as per Part 15 of the FCC Rules. These limits are designed to provide reasonable protection against harmful interference in a residential installation. This device uses and can radiate radio frequency energy and, if not installed and used in accordance with the included instructions, may cause harmful interference to radio communications. However, there is no guarantee that interference will not occur in a particular installation. If this device does cause harmful interference to radio or television reception, which can be determined by turning the device off and on, the user is encouraged to try to correct the interference by one or more of the following methods:

- Reorient or relocate the device.
- increase the separation between the device and the receiver.
- Connect the device to an electrical outlet on a circuit different from which the radio receiver is connected.
- Consult the dealer or an experienced radio/TV technician for help.

Energy Saving Matters (EuP 2009/125/EC)

Saving electric energy is a key to help protecting the environment. Please turn off all electrical products when they are not in use. To avoid power consumption in idle mode, disconnect all electrical equipment from power when not in use. Thank you!

